

Model 20309 VXibus Local Oscillator

Operation Manual

CCN 11901,11902,
11903

Manual Assy. Part Number: 5585497-01
Manual Text Part Number: 5580497-01
Printed in USA, January 2009

WARRANTY

Phase Matrix, Inc. warrants this product to be free from defects in material and workmanship for one year from the date of delivery. Damage due to accident, abuse, or improper signal level is not covered by the warranty. Removal, defacement, or alteration of any serial or inspection label, marking, or seal may void the warranty. Phase Matrix, Inc. will repair or replace, at its option, any components of this product which prove to be defective during the warranty period, provided the entire unit is returned to Phase Matrix, Inc. or an authorized service facility. In-warranty units will be returned freight prepaid; out-of-warranty units will be returned freight COLLECT. No warranty other than the above is expressed or implied.

CERTIFICATION

Phase Matrix, Inc. certifies this instrument to be in conformance with the specifications noted herein at time of shipment from the factory. Phase Matrix, Inc. further certifies that its calibration measurements are traceable to the United States National Institute of Standards and Technology.

MANUAL CHANGE INFORMATION

As Phase Matrix, Inc. continually improves and updates its products, changes to the material covered by the manual will occur. When a part or assembly in an Phase Matrix, Inc. instrument is changed to the extent that it is no longer interchangeable with the earlier part, the configuration control number (CCN) of the instrument, shown on the title page of the manual, will change, and a new edition of the manual will be published.

To maintain the technical accuracy of the manual, it may be necessary to provide new or additional information with the manual. In these cases, the manual is shipped with a Manual Update. Please be sure to incorporate the information as instructed in the Manual Update.

CONTACTING PHASE MATRIX

Phase Matrix, Inc.
Customer Support
109 Bonaventura Drive
San Jose, CA 95134

Tel: +1 (408) 428-1000
Toll free: +1 (877) 474-2736
Fax: +1 (408) 428-1500
Email: service@phasematrix.com
Web: www.phasematrix.com



SAFETY

The Phase Matrix 20309 is designed and tested according to international safety requirements, but as with all electronic equipment, certain precautions must be observed. This manual contains information, cautions, and warnings that must be followed to prevent the possibility of personal injury and/or damage to the instrument.

SAFETY AND HAZARD SYMBOLS

WARNING

A WARNING denotes a hazard to personnel. It calls attention to a procedure or practice, which, if not correctly performed or adhered to, could result in personal injury.

CAUTION

A CAUTION denotes a hazard to the equipment. It calls attention to an operating procedure or practice, which, if not correctly performed or adhered to, could result in damage to or destruction of part or all of the product.



This is a general warning that appears whenever care is necessary to prevent damage to the equipment.



Dangerous Voltage



Toxic Substance



Static-Sensitive Component



Fire Hazard

OVERALL SAFETY CONSIDERATIONS



WARNING

Before this instrument is powered on, its protective earth terminals *must* be in contact with the mainframe's protective conductor. The mainframe *must* be connected to a power source that has a protective earth contact. The protective action must not be negated by using an extension cord (power cable) or adapter that does not have a protective earth (grounding) conductor.

WARNING



Whenever it is likely that electrical protection is impaired, the instrument *must* be made inoperative and be secured against any unintended operation.

WARNING



All protective earth terminals, extension cords, autotransformers, and other devices connected to this instrument *must* be connected to a socket/outlet that has a protective earth contact. Any interruption of the protection causes a potential shock hazard that can result in personal injury.

WARNING



The power supply is energized whenever power is connected to this instrument. Internal adjustments or servicing that must be done with the power connected must be performed only by qualified personnel.

WARNING



Some of the components used in this instrument contain resins and other chemicals that give off toxic fumes if burned. Be sure to dispose of these items properly.

CAUTION



Some static-sensitive components are used in this instrument. These components can be damaged if handled incorrectly.



This Page Intentionally Left Blank

TABLE OF CONTENTS

| | |
|---|-------|
| WARRANTY | . iii |
| CERTIFICATION | . iii |
| MANUAL CHANGE INFORMATION | . iii |
| CONTACTING PHASE MATRIX | . iii |
| SAFETY | . iv |
| SAFETY AND HAZARD SYMBOLS | . iv |
| OVERALL SAFETY CONSIDERATIONS | . v |

SECTION 1: GENERAL INFORMATION

| | |
|--|-----|
| INTRODUCTION | 1-1 |
| OPERATING CONDITIONS | 1-1 |
| STORAGE | 1-2 |
| SPECIFICATIONS | 1-2 |
| OUTPUT | 1-2 |
| SPECTRAL PURITY | 1-2 |
| INTERNAL TIMEBASE OUTPUT | 1-3 |
| EXTERNAL TIMEBASE INPUT | 1-3 |
| GENERAL/MECHANICAL | 1-3 |
| VXIbus | 1-4 |
| OPTIONS | 1-4 |
| RELATED PRODUCTS | 1-4 |
| GENERAL/MECHANICAL (CONTINUED) | 1-4 |

SECTION 2: INSTALLATION

| | |
|---------------------------------------|-----|
| UNPACKING | 2-1 |
| SETTING THE LOGICAL ADDRESS | 2-1 |
| POWER AND COOLING | 2-2 |
| INSTALLATION | 2-2 |
| INCOMING OPERATIONAL CHECK | 2-3 |
| IF A PROBLEM OCCURS | 2-3 |
| SERVICE INFORMATION | 2-3 |
| PERIODIC MAINTENANCE | 2-3 |
| UNIT IDENTIFICATION | 2-3 |
| FACTORY SERVICE | 2-4 |
| SHIPPING INSTRUCTIONS | 2-4 |



**SECTION 3:
CONNECTORS AND INDICATORS**

INTRODUCTION 3-1

FRONT PANEL STATUS LEDs 3-2

FRONT PANEL CONNECTORS 3-2

 OUTPUT CONNECTORS 3-2

 LO 1 OUTPUT 3-2

 LO 2 OUTPUT 3-2

 LO 3 OUTPUT 3-2

 AUX LO OUTPUT 3-2

 10 MHZ REF OUTPUT 3-2

 INPUT CONNECTOR 3-2

 10 MHZ REF INPUT 3-2

**SECTION 4:
THEORY OF OPERATION**

INTRODUCTION 4-1

VXIbus INTERFACE AND CONTROL 4-3

INITIALIZATION AND RESETS 4-4

INTRODUCTION 5-1

**SECTION 5:
PROGRAMMING**

REQUIREMENTS 5-2

ERROR AND STATUS INFORMATION 5-2

FUNCTIONS 5-3

 PM20309_CLOSE 5-3

 PM20309_ERRORMESSAGE 5-5

 PM20309_GET_STATUS 5-7

 PM20309_INIT 5-9

 PM20309_REGISTER_STATUS 5-13

 PM20309_RESET 5-15

 PM20309_SET_LO1_STATE 5-17

 PM20309_SET_LO2_STATE 5-19

 PM20309_SET_LO3_STATE 5-21

 PM20309_SET_LO_CONTROL 5-23

 PM20309_SET_LO_FREQ 5-25

 PM20309_SET_REF 5-27

 PM20309_UPDATE_REGISTER_VALUE 5-29

INTRODUCTION 6-1

**SECTION 6:
HARDWARE REGISTER INTERFACE**

BASIC CONFIGURATION REGISTERS. 6-2
 MANUFACTURER ID REGISTER (READ-ONLY) 6-2
 DEVICE TYPE REGISTER (READ ONLY). 6-3
 STATUS/CONTROL REGISTER (READ-ONLY). 6-4
 OFFSET REGISTER FOR A24 (READ/WRITE) 6-4
 A16 REGISTERS 08_{HEX} - 3F_{HEX} NOT USED 6-4
A24 REGISTERS 6-4
 STATUS REGISTER (OFFSET 200_{HEX}) READ 6-5
 LO SYNTHESIZER CONTROL REGISTER (OFFSET 208_{HEX}) 6-6
 LO SYNTHESIZER (LO1) DATA REGISTER (OFFSET 20A_{HEX}) 6-7
 LOCAL OSCILLATOR 2 (LO 2) 6-7
 LOCAL OSCILLATOR 3 (LO 3) 6-7

**APPENDIX A:
VXIbus**

INTRODUCTION A-1
VMEbus BACKGROUND A-1
THE VXIbus EXTENSIONS A-2
 VXIbus MODULES. A-2
 VXIbus SUBSYSTEMS. A-3
 P2 CONNECTOR DEFINITION A-3
 P3 CONNECTOR DEFINITION A-3
 VXIbus SYSTEM ARCHITECTURE A-3

**APPENDIX B:
FUNCTIONAL BLOCK DIAGRAM**

FUNCTIONAL BLOCK DIAGRAM B-1



This Page Intentionally Left Blank

1

GENERAL INFORMATION

INTRODUCTION

The Phase Matrix Model 20309 Local Oscillator is a register-based VXI module capable of generating the local oscillator signals required by the companion model, the Phase Matrix 1313B Downconverter. Other than interface address switches, the instrument has no manual controls. It is normally controlled by a computer utilizing a simple register-based system. The 20309 is a VXIbus, C-size, plug-in module that requires a VXIbus mainframe for operation.

OPERATING CONDITIONS

The Phase Matrix 20309 Local Oscillator is designed to operate at temperatures from 0° C to 50° C at a relative humidity not exceeding 95% (75% over 25° C; 45% over 40° C). The unit performs to specifications at altitudes not exceeding 10,000 ft. (3050 m). It is fungus resistant. The module housings are not designed to provide protection from severe mechanical shock or liquids and are intended for normal VXIbus use in an environmentally clean area.

The 20309 Local Oscillator meets the requirements of MIL-T-28800D, Type III, Class 7, Style G, Color R with the following modifications and exceptions:

1. The non-operating temperature requirement is limited to the range of -40° C to +70° C.
2. The operating and non-operating altitude requirements are not invoked.
3. The EMI requirement is modified as follows:
 - a. For frequencies ≥ 1 GHz, RE02 of MIL-STD-461C applies.
 - b. For frequencies < 1 GHz, VXIbus System Specifications Revision 1.3/1.4 applies.
4. The warm-up time is 15 minutes at 25° C ambient temperature.



STORAGE

To prevent damage to the Local Oscillator, it must be stored in an antistatic bag or enclosure and in an environment that is protected from moisture, dust, and other contaminants. Do not expose the instrument to temperatures below -40°C or above $+70^{\circ}\text{C}$, altitudes above 40,000 ft. (12000 m), nor vibration exceeding 2 g.

SPECIFICATIONS

OUTPUT

| | |
|----------------------------------|-------------------------------------|
| LO1 Frequency Output | 3.0 to 9.0 GHz |
| LO2 Frequency Output | 3.25 GHz (factory-set) |
| LO3 Frequency Output | 228 MHz (factory-set) |
| LO1 Frequency Step Size | 1 Hz (true 1 Hz, binary type steps) |
| LO2 Frequency Step Size | N/A (fixed frequency) |
| LO3 Frequency Step Size | N/A (fixed frequency) |
| LO1 Frequency Switching Speed | 10 ms max. |
| Output Power (fixed) (LO1) | +10 dBm min. |
| Output Power (fixed) (LO2, LO3) | +1 dBm min. |
| Output Impedance (LO1, LO2, LO3) | 50 Ω nom. |

SPECTRAL PURITY

| | |
|--|-------------|
| Harmonics (LO1, LO2, LO3) | 15 dBc min. |
| Non-Harmonically Related Spurious | |
| 0.1 to 100 kHz from F_0 | 70 dBc min. |
| > 100 kHz | 75 dBc min. |
| Power-Line-Related Spurious | 40 dBc min. |
| Residual Modulation (50 Hz to 15kHz bandwidth) (LO1, LO2, LO3) | |
| FM | <200 Hz rms |
| AM | <0.1% peak |

SPECTRAL PURITY (Continued)

| | |
|---|------------------|
| Phase Noise (SSB, offset from F_0) (LO1, LO2, LO3) | |
| 100 Hz | -75 dBc/Hz max. |
| 1 kHz | -85 dBc/Hz max. |
| 10 kHz | -100 dBc/Hz max. |
| 100 kHz | -120 dBc/Hz max. |
| 1 MHz | -145 dBc/Hz max. |

INTERNAL TIMEBASE OUTPUT

| | |
|-----------------------------------|---|
| Frequency | 10 MHz |
| Aging Rate (after 72-hour warmup) | $< 1 \times 10^{-9}$ /day @ 25° C |
| Temperature Stability | $< 1 \times 10^{-7}$ over 0° C to 50° C range |
| Output Level | 0 dBm @ ± 3 dB |
| Output Impedance | 50 Ω nom. |
| Connector | SMA (f) |

EXTERNAL TIMEBASE INPUT

| | |
|-----------------------|--|
| Frequency | 1, 2, 5, or 10 MHz (automatically locks to externally applied signal) |
| Input Level | -3 dBm min. |
| Input Impedance | 50 Ω nom. |
| Input Level Tolerance | +10 dBm max. |
| Connector | SMA (f) |

GENERAL/MECHANICAL

| | |
|-----------------------------|---|
| Operating Temperature Range | 0° C to +50° C |
| Non-Operating Temperature | -40° C to +70° C |
| Humidity | 0% to 90%, Non-Condensing |
| Operating Altitude | 10,000 ft. |
| Non-Operating Altitude | 15,000 ft. |
| Vibration | Per MIL-PRF-28800 Class 1 enclosure, 5 to 55 Hz at 0.7 to 3 g |
| Safety | Designed for conformance with IEC-1010 |
| EMI | |
| Below 1 GHz | Complies with VXibus Revision 1.3/1.4 specifications |
| Above 1 GHz | Complies with RE02 of MIL-STD-461C |



GENERAL/MECHANICAL (Continued)

Connectors

| | |
|--------------------------|---------|
| External Timebase Input | SMA (f) |
| Internal Timebase Output | SMA (f) |
| LO 1, LO 2, LO 3 Output | SMA (f) |

Weight 8 lbs. max.

Mechanical Complies with VXIbus Revision 2.0 specifications

VXIbus

| | |
|--------------------|---|
| Module Size | C-Size, one slot |
| Device Type | Register-Based (A24) |
| Protocol | Not Used |
| Local Bus | Not Used |
| ECLTRG Utilization | Not Used |
| TTLTRG Utilization | Not Used |
| CLK10 Utilization | Not Used |
| Cooling | 1 mm H ₂ O @ 5 liters/second for 15° C internal temperature rise |
| Warm-up Time | 15 minutes max. @ +25° C ambient temperature |
| Power Disipation | 37 W typ., 50 W max. |

| | | | | | | | |
|------------|-------|-------|-------|------|--------|-------|-------|
| Voltage | +5 V | +12 V | +24 V | -2 V | -5.2 V | -12 V | -24 V |
| DC Current | 1.8 A | 0.8 A | 1.5 A | N/A | 0.1 A | N/A | N/A |

OPTIONS

| | |
|-----------|---|
| Option 01 | Aux. LO1 Output Connector 0 dBm min. |
| Option 02 | 2nd. Channel Coherent LO1, LO2, LO3 outputs |

RELATED PRODUCTS

| | |
|-------------|--|
| Model 1313B | 1 MHz to 26.5 GHz VXIbus Microwave Downconverter |
| Model 1140B | Synthesized Microwave Signal Source |

2

INSTALLATION

UNPACKING

Before unpacking the instrument, carefully inspect the shipping carton for any signs of damage. If the carton or instrument is damaged, immediately notify the shipper's agent. Remove the packing carton and supports, being careful not to scar or damage the instrument. Make a complete visual inspection of the instrument, checking for any damage or missing components. Report any problems to Phase Matrix immediately. Save the packing material for re-use if it becomes necessary to return the instrument to Phase Matrix for repair or calibration.

SETTING THE LOGICAL ADDRESS

Before installing the Local Oscillator in the VXIbus mainframe, set the instrument to a logical address between 1 and 254 (decimal). The factory-default setting for the logical address is 11 hexadecimal (17 decimal). You set the logical address of the 20309 with the two rotary hexadecimal switches located on the bottom of the module (see Figure 2-1).

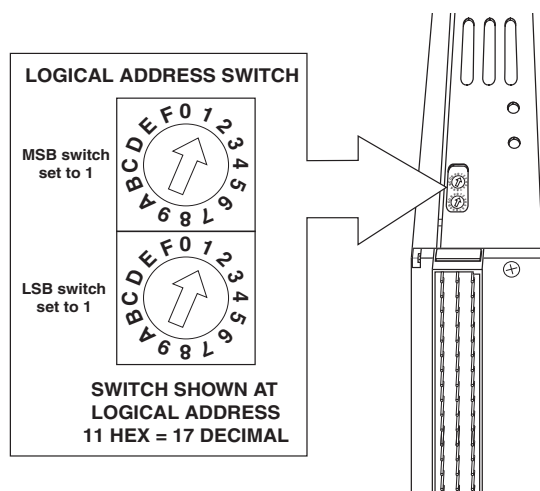

Figure 2-1. Logical Address Switch Locations (viewed from rear of module)



To set the logical address, set each switch to the appropriate hexadecimal value. For example, to set a logical address of 17 hexadecimal (23 decimal), use a small flat-blade screwdriver (or a similar tool) to rotate the most-significant-bit (MSB) switch to 1 and the least-significant-bit (LSB) switch to 7. The logical address must be a value between decimal 1 and 254. Logical address 0 is reserved for Slot 0 devices. Logical address 255 is reserved for dynamically configured devices. The Phase Matrix 20309 does not support dynamic configuration.

POWER AND COOLING

The Phase Matrix 20309 operates within an ambient temperature range from -10 to +50° C and can consume up to 50 watts (see “Specifications” in Section 1). When configuring your VXIbus system, ensure that the chassis has sufficient power and cooling capacity for the 20309 and the other instruments installed in the chassis (refer to the chassis specifications and cooling-capacity curves).

INSTALLATION

The 20309 is a VXIbus module that is designed to be installed in a VXIbus mainframe. Prior to installing the 20309 in a VXIbus mainframe, verify that all VXI-defined voltages are present and within limits, and make sure the mainframe is capable of supplying the required current (see “Specifications” in Section 1).

CAUTION



Prior to installing the 20309 in a VXIbus mainframe, verify that all the VXI-defined voltages are present and that the mainframe is capable of supplying the required current.

CAUTION



Do not plug the 20309 into a VXIbus mainframe with power applied.

The 20309 is a one-slot, C-size module that can be installed into any slot of a VXIbus mainframe except slot 0 (slot 0 is reserved for the resource manager). To install the 20309 into a VXIbus mainframe, turn the mainframe power off, place the 20309 card edges into the front guides at the top and bottom of the mainframe, and gently slide the 20309 towards the rear of the mainframe until the connectors just mate with the backplane. Firmly seat the module against the backplane connectors, and make sure the front panel is flush with the front of the card cage. Tighten the retaining screws to ensure the module remains fully seated. Numbers are located on a label on the side of the module, and they must be included in any correspondence regarding your equipment.

**CAUTION**

Do not use the retaining screws to seat the module.

INCOMING OPERATIONAL CHECK

AVXIbus mainframe, a slot-0 resource manager, and an instrument controller are required to verify that the downconverter is operational. With the downconverter installed in a VXIbus mainframe, two types of tests can be performed to verify proper operation.

1. Observe the state of the **Failed** LED. Whenever a VXIbus mainframe is energized, the resource manager queries each device checking for proper operation. The downconverter also performs a power-on self-test. The **Failed** LED lights during the self test or if any problems are detected.
2. Query the instrument regarding its operational status by using a controller to issue the self-test query, ***TST?**. The instrument returns a 0 if all tests pass.

IF A PROBLEM OCCURS

If a problem occurs, make the following checks before returning the instrument for repair:

1. Verify logical address setting on the instrument.
2. Verify that all specified VXI voltages are present.
3. If the unit has never worked in the particular system, the problem may be in the system rather than in the instrument. If this occurs, call Phase Matrix Customer Support at the phone number listed on page iii.

SERVICE INFORMATION

This section provides information regarding periodic maintenance, explains how to locate the identifying information for the 20309, and describes how to return the instrument to Phase Matrix for factory service.

PERIODIC MAINTENANCE

No periodic preventive maintenance is required.

UNIT IDENTIFICATION

The 20309 is identified by three sets of numbers: the model number (PM 20309), the serial number, and a configuration-control number (CCN). These numbers, which must be included in any correspondence regarding your 20309, are on a label on the side of the module.



FACTORY SERVICE

When returning a 20309 to Phase Matrix for service or repair, be sure to include the following information with the shipment:

- Name and address of owner
- Model, complete serial number, and CCN
- A complete description of the problem. Try to provide enough information so that the problem can be verified:
 - Under what conditions did the problem occur?
 - Did the unit work and then fail?
 - What other equipment was connected to the 20309 when the problem occurred?
- The name and telephone number of someone familiar with the problem who can be contacted by Phase Matrix if any further information is required
- The shipping address to which the unit is to be returned. Include any special shipping instructions.

SHIPPING INSTRUCTIONS

Place the 20309 in an antistatic bag or enclosure, wrap it in heavy plastic or kraft paper, and repack it in the original container, if available. If the original container cannot be used, pack in a heavy (275 pound test), double-walled carton with approximately four inches of packing material between the unit and the inner carton. Seal the carton with strong filament tape or strapping. Mark the carton to indicate that it contains a fragile electronic instrument. Ship the package to Phase Matrix at the following address:

Phase Matrix, Inc.
109 E. Bonaventura Dr.
San Jose, CA 95134

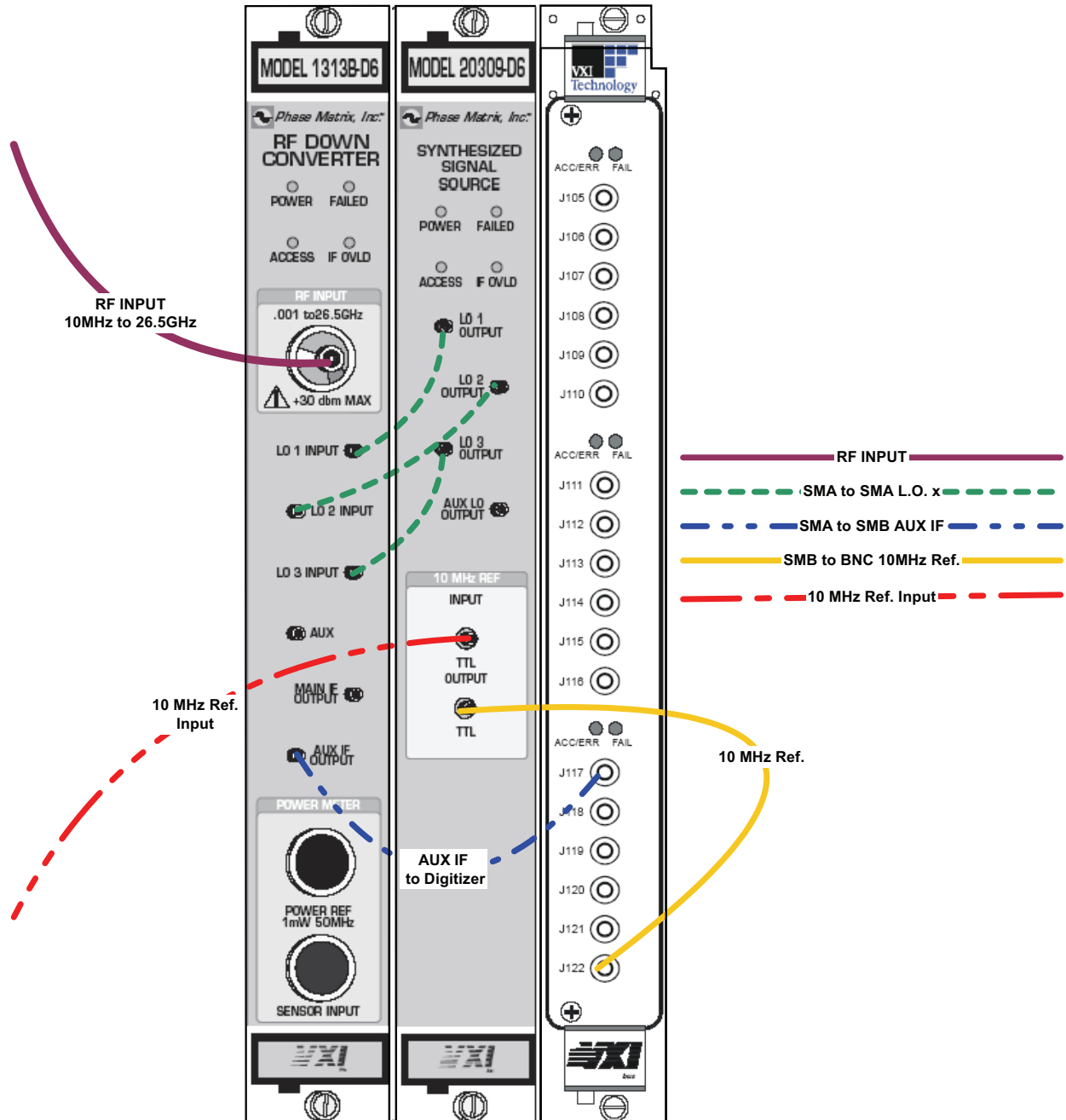

Figure 2-1. Installation Example: 1313B Downconverter, 20309 Synthesizer, and VXITech 2601 Digitizer



This Page Intentionally Left Blank

3

CONNECTORS AND INDICATORS

INTRODUCTION

This section describes the functions of the front-panel LED indicators and connectors. The front panel of the 20309 is shown in Figure 3-1.

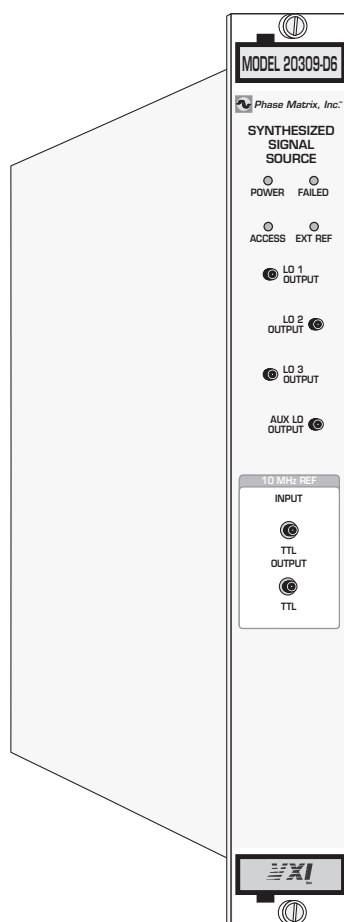

Figure 3-1. 20309 Synthesized Signal Source



FRONT PANEL STATUS LEDs

- **POWER LED:** This LED lights whenever all required power is being supplied to the Model 20309 Synthesized Signal Source. The 20309 senses the voltage on all lines that are used and checks for sufficient voltage. If the required voltages are not present, the LED does not light.
- **FAILED LED:** This LED lights if the 20309 has failed. Failures typically result from internal component failure or inadequate power-supply current. The **FAILED** LED follows the condition of the VXIbus **SYSFAIL** line. If the unit fails, the LED remains lit, even if **SYSFAIL** is inhibited by the commander.
- **ACCESS LED:** This LED lights when a commander is accessing the 20309's VXIbus registers.
- **EXT REF LED:** This LED lights to indicate that the 20309 is in external-reference mode.

FRONT PANEL CONNECTORS

The 20309 has five output connectors and one input connector. All connectors are SMA (f).

OUTPUT CONNECTORS

LO 1 OUTPUT

This is the LO 1 frequency output (3.0 to 9.0 GHz).

LO 2 OUTPUT

This is the LO 2 frequency output (3.25 GHz, factory-set).

LO 3 OUTPUT

This is the LO 3 frequency output (228 MHz, factory-set).

AUX LO OUTPUT

This is an auxilliary output of LO 1 (approximately 15 dB lower power level).

10 MHZ REF OUTPUT

This is the internal timebase output (10 MHz at approximately 0 dBm).

INPUT CONNECTOR

10 MHZ REF INPUT

This is the input for an external-reference signal.

THEORY OF OPERATION

INTRODUCTION

The Phase Matrix Model 20309 Synthesized Signal Source is a register-based VXI module capable of generating the local-oscillator signals required by the companion Phase Matrix 1313B Downconverter. The 20309 is a special model within the 20309 family. Under register-based control, its phase-locked oscillators generate a switchable 3 – 9 GHz LO1 signal with 1 Hz resolution, a fixed 3.25 GHz LO2 signal, and a fixed 228 MHz LO3 signal.

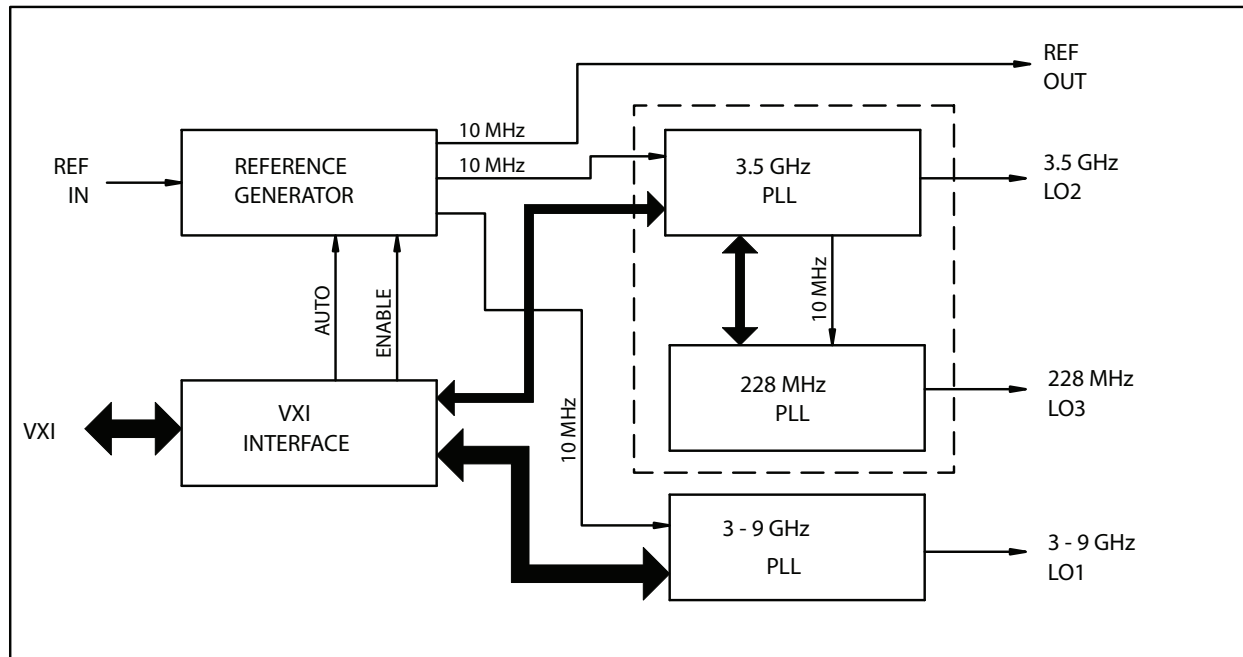

Figure 4-1. 20309 Overall Block Diagram



The three Phase-Locked Loops are locked to an internal, 10 MHz, crystal-controlled timebase which can be locked to an external reference signal. A 10 MHz reference output available at the front panel is also generated. This output can be turned on and off under software control.

The First Local Oscillator (LO1) covers a frequency range of 3.0 to 9.0 GHz in 1 Hz steps. It is a YIG-tuned synthesizer and, as such, its current consumption is a function of frequency. It is recommended that LO1 be tuned to its lowest frequency when it is not in use. This results in saving up to 600 ma (compared to the current consumption at the highest frequency).

The Second and Third Local Oscillators (LO2 and L03) are packaged as a single assembly, with LO3 taking its power, reference, and control from the LO2 assembly, which is connected to the VXI interface. LO2 generates a fixed 3.25 GHz output, while LO3 generates a 228 MHz output.

Communication and control of the LO2 and LO3 module is limited to enabling and disabling the outputs and reporting lock indications from the synthesizers.

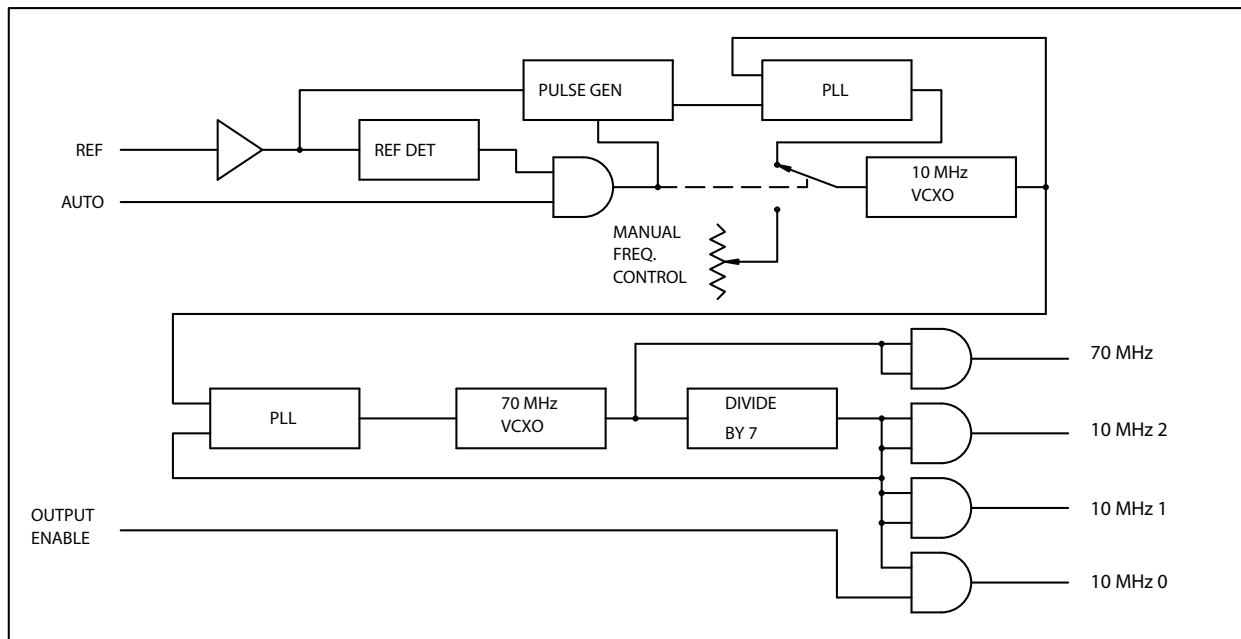

Figure 4-2. Reference Generator Diagram

Under software control, the internal reference can be manually selected, or the reference generator can be placed in an Automatic mode, wherein it detects the presence of a reference signal and locks to it. The internal reference is set to an accurate frequency standard during the manufacturing process, and its accuracy and stability over time are as specified in Section 1 of this manual.

A 70 MHz VCXO is locked to the 10 MHz reference. Its output is then divided by seven to produce the 10 MHz reference outputs described above. The reason for this second loop-and-divider circuit is to minimize the phase noise of the references thus generated.

The outputs are buffered by TTL-level amplifiers and have an output impedance of 100 ohms, except for the switched output, which is supplied to the front panel connector and has an output impedance of 50 ohms.

VXIbus INTERFACE AND CONTROL

The 20309 Interface and Control module carries all of the logic circuitry necessary to communicate with the controller via the VXIbus and to control the RF circuitry. It also contains the voltage regulators. The VXIbus Interface IC, IT9010, is central to the Interface and Control module. It performs all of the communications functions necessary to incorporate the 20309 into a VXI environment, and in conjunction with a Programmable Logic Device (PLD), it controls the RF circuitry. Use of a register-based programming system obviates the need for a processor with its attendant hardware and software overhead.

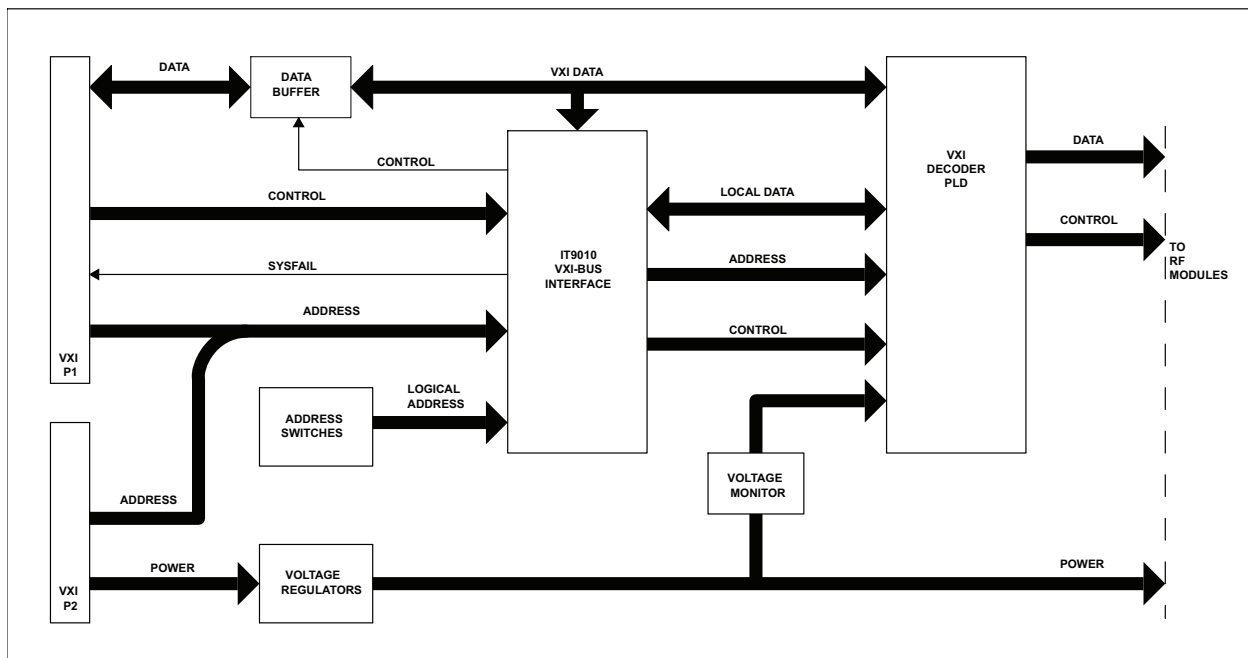

Figure 4-3. VXIbus Interface and Control

Other than the special case of a SYSFAIL alert, the Interface and Control module has no ability to initiate a communication with the rest of the VXI system. It reacts and responds only to commands sent to it. Any data it reports to the system controller is in direct response to a query from the controller. In addition to certain operational status reports, it can also report the Phase Matrix VXI Identifier Code, 3680 (E60h), and the model information, 309 (135_{HEX}), which is stored in the PLD.

Commands are sent to the 20309 by writing an appropriate value (data) to an appropriate register (address).



The 20309 utilizes both A16 and A24 addressing. The A16 address space contains the information used in initializing the system. The A24 address space contains the command and response information that is used to control the 20309.

When the 20309 is installed, address switches are set to the logical address of the unit (see Section 2, "Installation"). During initialization, the VXI controller reads the logical address. From this, it calculates a base address for the A16 address space. The actual A16 registers are identified in the host computer as offsets to this base address. The user needs only to program these offsets. The VXI system controller (Slot 0 card) adds the base to the offset to generate the complete address.

In the initialization process, the VXI system controller reads the memory requirement of the 20309 (and all other units in the VXI system) and calculates and assigns a base address for the A24 address space, which is stored in the Offset Register.

When programming the 20309, a register is identified by an Offset Address. When the host computer sends a command to the unit, the VXI controller concatenates the Offset Register value with the Offset Address of the particular command. The result is the complete address of the appropriate A24 register in the 20309.

Data communication between the 20309 and the rest of the VXI system is controlled by a bi-directional Data Buffer, which connects the 20309's internal data bus to the VXI data bus in the appropriate (read/write) direction under the control of the VXI Interface IC, which, in turn, is responding to a command from the VXI system controller. Both the VXI Interface IC and the PLD can read from or write to the bus. Additionally, there is a local bus between the VXI Interface IC and the PLD, which is under the control of the VXI Interface IC.

Data and control to the RF circuitry originates in the PLD and is supplied to the various switches and logically controllable devices in response to commands sent to the PLD registers by the VXI System Controller.

Additionally, the outputs of the voltage regulators are monitored, and an error signal is sent to the PLD should any of the voltages become out of tolerance.

INITIALIZATION AND RESETS

The 20309 contains no internal memory. Hence, on initial start-up or after a system reset, it retains nothing of its previous operating state. The unit starts in a pseudo-random state, and its outputs are not, generally speaking, usable; i.e., the outputs do not match the input requirements of the companion 1313B until both units are initialized by writing the necessary state data to the instruments' A24 addresses.

5

PROGRAMMING

INTRODUCTION

The 20309 instrument driver provides programming support for Phase Matrix's 20309 Local Oscillator. It contains functions for opening, configuring, taking measurements from, and closing the instrument. The information herein describes each function of the 20309 driver. The functions appear in alphabetical order with a description of the function and its C syntax, a description of each parameter, and a list of possible error codes. The driver is divided into the following functions and classes:

1. Initialize:

This function initializes the instrument and sets it to a default configuration.

2. Application Functions: (Class)

This class contains high-level, test and measurement routines. These examples call other instrument driver functions to configure, start, and read from the instrument.

3. Configuration Functions: (Class)

This class of functions configures the instrument by setting acquisition and system configuration parameters.

4. Action/Status Functions: (Class)

This class of functions begins or terminates an acquisition. It also provides functions which allow the user to determine the current status of the instrument.

5. Data Functions: (Class)

This class of functions transfers data to or from the instrument.

6. Utility Functions: (Class)



This class of functions provides lower level functions to communicate with the instrument, and change instrument parameters.

7. Close:

This function takes the instrument offline.

REQUIREMENTS

To successfully use the 20309 instrument module, the following conditions must be met:

- For GPIB instrument drivers:
 - the instrument is connected to the GPIB.
 - the GPIB address supplied to the initialize function must match the GPIB address of the instrument.
- For VXI instrument drivers:
 - the instrument is installed in the VXI mainframe and one of the following controller options is being used:
 - Embedded controller
 - MXI
 - MXI2
 - GPIB-VXI
 - the logical address supplied to the initialize function must match the logical address of the instrument.
- For RS-232 instrument drivers:
 - the instrument is connected to the RS-232 interface.
 - the COM port, baud rate, parity, and timeout supplied to the initialize function must match the settings of the instrument.

ERROR AND STATUS INFORMATION

Each function in the driver returns a status code that either indicates success or describes an error or warning condition. The status code from each call to a driver function should be examined to determine if an error has occurred within the developed program. The description of each instrument driver function lists possible error codes and their meanings. The general meaning of the status code is as follows:

| <u>Value</u> | <u>Meaning</u> |
|-----------------|----------------|
| 0 | Success |
| Positive Values | Warnings |
| Negative Values | Errors |

FUNCTIONS

PM20309_CLOSE

```
ViStatus PM20309_close (ViSession instrumentHandle);
```

PURPOSE

This function performs **viClose (instrSession)** and **viClose (rmSession)**.

NOTE

The instrument must be reinitialized in order to use it again.

PARAMETER LIST

instrumentHandle

Variable Type: **ViSession**

This control accepts the **InstrumentHandle** returned by the **Initialize** function to select the desired instrument driver session.

Default Value: None

RETURN VALUE

This control contains the status code returned by the function call.

Status Codes:

| <u>Status</u> | <u>Description</u> |
|---------------|---|
| 0 | No error (the call was successful). |
| 3FFF0005 | The specified termination character was read. |
| 3FFF0006 | The specified number of bytes was read. |
| BFFF0000 | Miscellaneous or system error occurred. |
| BFFF000E | Invalid session handle. |
| BFFF0015 | Timeout occurred before operation could complete. |
| BFFF0034 | Violation of raw write protocol occurred. |
| BFFF0035 | Violation of raw read protocol occurred. |
| BFFF0036 | Device reported an output protocol error. |

| | |
|----------|---|
| BFFF0037 | Device reported an input protocol error. |
| BFFF0038 | Bus error occurred during transfer. |
| BFFF003A | Invalid setup (attributes are not consistent). |
| BFFF005F | No listeners condition was detected. |
| BFFF0060 | This interface is not the controller in charge. |
| BFFF0067 | Operation is not supported on this session. |

PM20309_ERRORMESSAGE

```
ViStatus PM20309_errorMessage (ViSession instrumentHandle, ViStatus errorCode,  
ViChar _VI_FAR errorMessage[]);
```

PURPOSE

This function takes the status code returned by the instrument driver functions, interprets it, and returns it as a user readable string.

PARAMETER LIST

instrumentHandle

Variable Type: **ViSession**

This control accepts the **Instrument Handle** returned by the **Initialize** function to select the desired instrument driver session.

Default Value: **VI_NULL**

errorCode

Variable Type: **ViStatus**

This control accepts the status code returned from the instrument driver functions.

Default Value: **0 - VI_SUCCESS**

errorMessage

Variable Type: **ViChar[]**

This control returns the interpreted status code as a user-readable message string.

NOTE

The array must contain at least 256 elements ViChar[256].

RETURN VALUE

This control contains the status code returned by the function call.

Status Codes:

| <u>Status</u> | <u>Description</u> |
|---------------|-------------------------------------|
| 0 | No error (the call was successful). |

| | |
|----------|---|
| 3FFF0005 | The specified termination character was read. |
| 3FFF0006 | The specified number of bytes was read. |
| 3FFF0085 | VI_WARN_UNKNOWN_STATUS |
| BFFF0000 | Miscellaneous or system error occurred. |
| BFFF000E | Invalid session handle. |
| BFFF0015 | Timeout occurred before operation could complete. |
| BFFF0034 | Violation of raw write protocol occurred. |
| BFFF0035 | Violation of raw read protocol occurred. |
| BFFF0036 | Device reported an output protocol error. |
| BFFF0037 | Device reported an input protocol error. |
| BFFF0038 | Bus error occurred during transfer. |
| BFFF003 | AInvalid setup (attributes are not consistent). |
| BFFF005F | No listeners condition was detected. |
| BFFF0060 | This interface is not the controller in charge. |
| BFFF0067 | Operation is not supported on this session. |

PM20309_GET_STATUS

```
ViStatus PM20309_get_status (ViSession instrumentHandle, ViChar _VI_FAR  
instrumentStatus[]);
```

PURPOSE

This function reads the instrument's status:

Status Strings:

0. +10 Volt Supply (VXI Power Supply Voltage)
1. +21 Volt Supply (VXI Power Supply Voltage)
2. -21 Volt Supply (VXI Power Supply Voltage)
3. -10 Volt Supply (VXI Power Supply Voltage)
4. +5 Volt Supply (VXI Power Supply Voltage)
5. Always high (not used)
6. Always high (not used)
7. Always high (not used)
8. Always high (not used)
9. Always high (not used)
10. Always high (not used)
11. Always high (not used)
12. LO 1 Lock Detect (Indicates that 3-9 GHz LO is locked)
13. LO 2 Lock Detect (Indicates that 3.25 GHz LO is Locked)
14. LO 3 Lock Detect (Indicates that 228 MHz LO is Locked)
15. LO 1 BUSY
 - 1 - LO1 Synthesizer is busy and can not accept data.
 - 0 - LO1 Synthesizer is ready to accept data.

PARAMETER LIST

instrumentHandle

Variable Type: **viSession**

This control accepts the **InstrumentHandle** returned by the **Initialize** function to select the desired instrument driver session.

Default Value: None

instrumentStatus

Variable Type: **viChar[]**

This control displays the current status of the instrument.

RETURN VALUE

This control contains the status code returned by the function call.

Status Codes:

| <u>Status</u> | <u>Description</u> |
|---------------|---|
| 0 | No error (the call was successful). |
| 3FFF0005 | The specified termination character was read. |
| 3FFF0006 | The specified number of bytes was read. |
| BFFF0000 | Miscellaneous or system error occurred. |
| BFFF000E | Invalid session handle. |
| BFFF0015 | Timeout occurred before operation could complete. |
| BFFF0034 | Violation of raw write protocol occurred. |
| BFFF0035 | Violation of raw read protocol occurred. |
| BFFF0036 | Device reported an output protocol error. |
| BFFF0037 | Device reported an input protocol error. |
| BFFF0038 | Bus error occurred during transfer. |
| BFFF003A | Invalid setup (attributes are not consistent). |
| BFFF005F | No listeners condition was detected. |
| BFFF0060 | This interface is not the controller in charge. |
| BFFF0067 | Operation is not supported on this session. |

PM20309_INIT

```
ViStatus PM20309_init (ViRsrc resourceName, ViBoolean IDQuery, ViBoolean  
reset, ViPSession instrumentHandle, ViPInt16 model);
```

PURPOSE

This function performs the following initialization actions:

- Opens a session to the default resource manager resource and a session to the specified device using the interface and address specified in the **Resource_Name** control.
- Performs an identification query on the instrument.
- Resets the instrument to a known state.
- Sends initialization commands to the instrument that set any necessary programmatic variables such as headers off, short command form, and data transfer binary to the state necessary for the operation of the instrument driver.
- Returns an **InstrumentHandle**, which is used to differentiate between different sessions of this instrument driver.
- Each time this function is invoked, a unique session is opened. It is possible to have more than one session open for the same resource.

PARAMETER LIST

resourceName

Variable Type: **ViRsrc**

This control specifies the interface and address of the device that is to be initialized (instrument descriptor). The exact grammar to be used in this control is shown below.

Default Value: "**GPIB::1**"

NOTE

Based on the instrument descriptor, this operation establishes a communication session with a device. The grammar for the instrument descriptor is shown below. Optional parameters are shown in square brackets ([]).

Interface Grammar:

GPIB GPIB[board]::primary address[::secondary address][::INSTR]

The GPIB keyword is used with GPIB instruments. The default value for optional parameters are shown below.

| <u>Optional Parameter</u> | <u>Default Value</u> |
|---------------------------|----------------------|
| board | 0 |
| secondary address | none - 31 |

IDQuery

Variable Type: **ViBoolean**

This control specifies if an ID query is sent to the instrument during the initialization procedure.

Valid Range:

- VI_OFF (0) - Skip Query
- VI_ON(1) - Do Query (Default Value)

NOTE

Under normal circumstances, the ID query ensures that the instrument initialized is the type supported by this driver. However, circumstances may arise when it is undesirable to send an ID query to the instrument. In those cases, set this control to "Skip Query," and this function will initialize the selected interface without doing an ID query.

reset

Variable Type: **ViBoolean**

This control specifies if a **reset** is sent to the instrument during the initialization procedure.

Valid Range:

- VI_OFF (0) - Skip Reset
- VI_ON(1) - Do Reset (Default Value)

instrumentHandle

Variable Type: **ViSession** (passed by reference)

This control returns an **InstrumentHandle** that is used in all subsequent function calls to differentiate between different sessions of the instrument driver.

NOTE

Each time this function is invoked, a unique session is opened. It is possible to have more than one session open for the same resource.

model

Variable Type: **viInt16** (passed by reference)

RETURN VALUE

This control contains the status code returned by the function call.

Status Codes:

| <u>Status</u> | <u>Description</u> |
|---------------|--|
| 0 | No error (the call was successful). |
| 3FFC0101 | ID Query not supported - VI_WARN_NSUP_ID_QUERY |
| 3FFC0102 | Reset not supported - VI_WARN_NSUP_RESET |
| 3FFC0103 | Self Test not supported - VI_WARN_NSUP_SELF_TEST |
| 3FFC0104 | Error Query not supported - VI_WARN_NSUP_ERROR_QUERY |
| 3FFC0105 | Revision Query not supported - VI_WARN_NSUP_REV_QUERY |
| 3FFF0005 | The specified termination character was read. |
| 3FFF0006 | The specified number of bytes was read. |
| BFFC0001 | Parameter 1 out of range. (String not range checked) |
| BFFC0002 | Parameter 2 (ID Query) out of range. |
| BFFC0003 | Parameter 3 (Reset Device) out of range. |
| BFFC0004 | Parameter 4 out of range. |
| BFFC0005 | Parameter 5 out of range. |
| BFFC0006 | Parameter 6 out of range. |
| BFFC0007 | Parameter 7 out of range. |
| BFFC0008 | Parameter 8 out of range. |
| BFFC0011 | Instrument returned invalid response to ID Query |
| BFFC0800 | Error Opening File VI_ERROR_INSTR_FILE_OPEN |
| BFFC0801 | Error Writing to File VI_ERROR_INSTR_FILE_WRITE |
| BFFC0803 | Invalid Response VI_ERROR_INSTR_INTERPRETING_RESPONSE |
| BFFC0809 | Parameter 9 out of range. VI_ERROR_INSTR_PARAMETER9 |
| BFFC080A | Parameter 10 out of range. VI_ERROR_INSTR_PARAMETER10 |
| BFFC080B | Parameter 11 out of range. VI_ERROR_INSTR_PARAMETER11 |
| BFFC080C | Parameter 12 out of range. VI_ERROR_INSTR_PARAMETER12 |
| BFFF0000 | Miscellaneous or system error occurred. |

| | |
|----------|---|
| BFFF000E | Invalid session handle. |
| BFFF0015 | Timeout occurred before operation could complete. |
| BFFF0034 | Violation of raw write protocol occurred. |
| BFFF0035 | Violation of raw read protocol occurred. |
| BFFF0036 | Device reported an output protocol error. |
| BFFF0037 | Device reported an input protocol error. |
| BFFF0038 | Bus error occurred during transfer. |
| BFFF003A | Invalid setup (attributes are not consistent). |
| BFFF005F | No listeners condition was detected. |
| BFFF0060 | This interface is not the controller in charge. |
| BFFF0067 | Operation is not supported on this session. |

NOTE

Parameter error codes for parameters 1 through 8 are defined in the `vpptype.h` header file. The range is `BFFC0001 - BFFC0008`. Parameter error codes for parameters 9 through 15 are defined in the instrument driver's header file. the range is `BFFC0809 - BFFC080F`. For parameter errors greater than 15 and other instrument-specific error codes, use an error code in the range of `BFFC0900 to BFFC0FFF`. This is equivalent to using `(VI_ERROR_INSTR_OFFSET + n)` where `n` represents each instrument specific error number. Valid ranges for `n` are 0 to `6FF`. (All values are given in Hexadecimal Notation.)

NOTE

Delete all unused status codes from the status control of each function panel when you are finished with development of your instrument driver. For example, in this control the status codes for parameters 1, 3-8, and the codes for error opening and writing to file should be deleted. These status codes are provided here for convenience during driver development.

PM20309_REGISTER_STATUS

```
ViStatus PM20309_register_status (ViSession instrumentHandle,ViPUInt16  
synthLOCtrlReg_Offset208H,ViPUInt16 synthLODataReg_Offset20AH,ViPUInt16  
statusReg_Offset200HRead);
```

PURPOSE

This function allows the user to query the low-level register status of all of the registers used with the downconverter. This function can be used to check the register values set on the downconverter for monitoring purposes.

PARAMETER LIST

instrumentHandle

Variable Type: **ViSession**

This control accepts the **InstrumentHandle** returned by the **Initialize** function to select the desired instrument driver session.

Default Value: None

synthLOCtrlReg_Offset208H

Variable Type : **ViUInt16** (passed by reference)

This control reads the synthesizer LO control register values offset from 208H.

synthLODataReg_Offset20AH

Variable Type: **ViUInt16** (passed by reference)

This control reads the synthesizer control register values offset from 20AH.

statusReg_Offset200HRead

Variable Type: **ViUInt16** (passed by reference)

This control reads the status register values offset from 202H.

RETURN VALUE

This control contains the status code returned by the function call.

Status Codes:

| <u>Status</u> | <u>Description</u> |
|---------------|---|
| 0 | No error (the call was successful). |
| 3FFF0005 | The specified termination character was read. |
| 3FFF0006 | The specified number of bytes was read. |
| BFFF0000 | Miscellaneous or system error occurred. |
| BFFF000E | Invalid session handle. |
| BFFF0015 | Timeout occurred before operation could complete. |
| BFFF0034 | Violation of raw write protocol occurred. |
| BFFF0035 | Violation of raw read protocol occurred. |
| BFFF0036 | Device reported an output protocol error. |
| BFFF0037 | Device reported an input protocol error. |
| BFFF0038 | Bus error occurred during transfer. |
| BFFF003A | Invalid setup (attributes are not consistent). |
| BFFF005F | No listeners condition was detected. |
| BFFF0060 | This interface is not the controller in charge. |
| BFFF0067 | Operation is not supported on this session. |

PM20309_RESET

```
ViStatus PM20309_reset (ViSession instrumentHandle);
```

PURPOSE

This function resets the instrument to a known state and sends initialization commands to the instrument that set any necessary programmatic variables such as headers off, short command form, and data transfer binary to the state necessary for the operation of the instrument driver.

NOTE

If the instrument does not support a reset, this function should return the Warning Code 0x3FFC0102 - VI_WARN_NSUP_RESET.

PARAMETER LIST

instrumentHandle

Variable Type: **ViSession**

This control accepts the **InstrumentHandle** returned by the **Initialize** function to select the desired instrument driver session.

Default Value: None

RETURN VALUE

This control contains the status code returned by the function call.

Status Codes:

| <u>Status</u> | <u>Description</u> |
|---------------|---|
| 0 | No error (the call was successful). |
| 3FFC0102 | Reset not supported - VI_WARN_NSUP_RESET |
| 3FFF0005 | The specified termination character was read. |
| 3FFF0006 | The specified number of bytes was read. |
| BFFF0000 | Miscellaneous or system error occurred. |
| BFFF000E | Invalid session handle. |
| BFFF0015 | Timeout occurred before operation could complete. |
| BFFF0034 | Violation of raw write protocol occurred. |
| BFFF0035 | Violation of raw read protocol occurred. |

| | |
|----------|---|
| BFFF0036 | Device reported an output protocol error. |
| BFFF0037 | Device reported an input protocol error. |
| BFFF0038 | Bus error occurred during transfer. |
| BFFF003A | Invalid setup (attributes are not consistent). |
| BFFF005F | No listeners condition was detected. |
| BFFF0060 | This interface is not the controller in charge. |
| BFFF0067 | Operation is not supported on this session. |

PM20309_SET_LO1_STATE

```
ViStatus PM20309_set_lo1_state (ViSession instrumentHandle, ViBoolean
LO1State);
```

PURPOSE

This function sets the LO1_PWR State to ON or OFF.

PARAMETER LIST

instrumentHandle

Variable Type: **ViSession**

This control accepts the **InstrumentHandle** returned by the **Initialize** function to select the desired instrument driver session.

Default Value: None

LO1State

Variable Type: **ViBoolean**

This control allows you to set the LO State to ON or OFF.

RETURN VALUE

This control contains the status code returned by the function call.

Status Codes:

| <u>Status</u> | <u>Description</u> |
|---------------|---|
| 0 | No error (the call was successful). |
| 3FFF0005 | The specified termination character was read. |
| 3FFF0006 | The specified number of bytes was read. |
| BFFF0000 | Miscellaneous or system error occurred. |
| BFFF000E | Invalid session handle. |
| BFFF0015 | Timeout occurred before operation could complete. |
| BFFF0034 | Violation of raw write protocol occurred. |
| BFFF0035 | Violation of raw read protocol occurred. |
| BFFF0036 | Device reported an output protocol error. |
| BFFF0037 | Device reported an input protocol error. |

| | |
|----------|---|
| BFFF0038 | Bus error occurred during transfer. |
| BFFF003A | Invalid setup (attributes are not consistent). |
| BFFF005F | No listeners condition was detected. |
| BFFF0060 | This interface is not the controller in charge. |
| BFFF0067 | Operation is not supported on this session. |

PM20309_SET_LO2_STATE

```
ViStatus PM20309_set_lo2_state (ViSession instrumentHandle, int LO2State);
```

PURPOSE

This function sets the LO2_PWR State to ON or OFF.

PARAMETER LIST

instrumentHandle

Variable Type: **ViSession**

This control accepts the **InstrumentHandle** returned by the **Initialize** function to select the desired instrument driver session.

Default Value: None

LO2State

Variable Type: int

This control allows you to set the LO state to ON or OFF.

RETURN VALUE

This control contains the status code returned by the function call.

Status Codes:

| <u>Status</u> | <u>Description</u> |
|---------------|---|
| 0 | No error (the call was successful). |
| 3FFF0005 | The specified termination character was read. |
| 3FFF0006 | The specified number of bytes was read. |
| BFFF0000 | Miscellaneous or system error occurred. |
| BFFF000E | Invalid session handle. |
| BFFF0015 | Timeout occurred before operation could complete. |
| BFFF0034 | Violation of raw write protocol occurred. |
| BFFF0035 | Violation of raw read protocol occurred. |
| BFFF0036 | Device reported an output protocol error. |
| BFFF0037 | Device reported an input protocol error. |
| BFFF0038 | Bus error occurred during transfer. |

| | |
|----------|---|
| BFFF003A | Invalid setup (attributes are not consistent). |
| BFFF005F | No listeners condition was detected. |
| BFFF0060 | This interface is not the controller in charge. |
| BFFF0067 | Operation is not supported on this session. |

PM20309_SET_LO3_STATE

```
ViStatus PM20309_set_lo3_state (ViSession instrumentHandle, int LO3State);
```

PURPOSE

This function sets the LO3_PWR State to ON or OFF.

PARAMETER LIST

instrumentHandle

Variable Type: **ViSession**

This control accepts the **InstrumentHandle** returned by the **Initialize** function to select the desired instrument driver session.

Default Value: None

LO3State

Variable Type int

This control allows you to set the LO state to ON or OFF.

RETURN VALUE

This control contains the status code returned by the function call.

Status Codes:

| <u>Status</u> | <u>Description</u> |
|---------------|---|
| ON | o error (the call was successful). |
| 3FFF0005 | The specified termination character was read. |
| 3FFF0006 | The specified number of bytes was read. |
| BFFF0000 | Miscellaneous or system error occurred. |
| BFFF000E | Invalid session handle. |
| BFFF0015 | Timeout occurred before operation could complete. |
| BFFF0034 | Violation of raw write protocol occurred. |
| BFFF0035 | Violation of raw read protocol occurred. |
| BFFF0036 | Device reported an output protocol error. |
| BFFF0037 | Device reported an input protocol error. |
| BFFF0038 | Bus error occurred during transfer. |

| | |
|----------|---|
| BFFF003A | Invalid setup (attributes are not consistent). |
| BFFF005F | No listeners condition was detected. |
| BFFF0060 | This interface is not the controller in charge. |
| BFFF0067 | Operation is not supported on this session. |

PM20309_SET_LO_CONTROL

```
ViStatus PM20309_set_lo_control (ViSession instrumentHandle, ViUInt16  
synthesizerLOCtrl);
```

PURPOSE

This function sets the LO synthesizer to the following modes:

- LO_RESET (resets the LO synthesizer microprocessor)
- LO_SELECT (allows transmission of data to the LO synthesizer)

PARAMETER LIST

instrumentHandle

Variable Type: **ViSession**

This control accepts the **InstrumentHandle** returned by the **Initialize** function to select the desired instrument driver session.

Default Value: None

synthesizerLOCtrl

Variable Type: **ViUInt16**

This control specifies the LO synthesizer to the following modes:

- LO_RESET (resets the LO synthesizer microprocessor)
- LO_SELECT (allows transmission of data to the LO synthesizer)

Variable type: **ViUInt16**

Valid Range:

- PM131xA_Display_Resolution_BW_250MHz0
- PM131xA_Display_Resolution_BW_100MHz4096
- PM131xA_Display_Resolution_BW_50MHz 8192
- PM131xA_Display_Resolution_BW_5MHz12288
- PM131xA_Display_Resolution_BW_500KHz16384
- PM131xA_Display_Resolution_BW_50KHz 20480

Default:

- PM131xA_Display_Resolution_BW_500KHz16384

RETURN VALUE

This control contains the status code returned by the function call.

Status Codes:

| <u>Status</u> | <u>Description</u> |
|---------------|---|
| 0 | No error (the call was successful). |
| 3FFF0005 | The specified termination character was read. |
| 3FFF0006 | The specified number of bytes was read. |
| BFFF0000 | Miscellaneous or system error occurred. |
| BFFF000E | Invalid session handle. |
| BFFF0015 | Timeout occurred before operation could complete. |
| BFFF0034 | Violation of raw write protocol occurred. |
| BFFF0035 | Violation of raw read protocol occurred. |
| BFFF0036 | Device reported an output protocol error. |
| BFFF0037 | Device reported an input protocol error. |
| BFFF0038 | Bus error occurred during transfer. |
| BFFF003A | Invalid setup (attributes are not consistent). |
| BFFF005F | No listeners condition was detected. |
| BFFF0060 | This interface is not the controller in charge. |
| BFFF0067 | Operation is not supported on this session. |

PM20309_SET_LO_FREQ

```
ViStatus PM20309_set_lo_freq (ViSession instrumentHandle, ViReal64
lOfrequency_GHz);
```

PURPOSE

This function sends data to the L.O. control.

PARAMETER LIST

instrumentHandle

Variable Type: **ViSession**

This control accepts the **InstrumentHandle** returned by the **Initialize** function to select the desired instrument driver session.

Default Value: None

lOfrequency_GHz

Variable Type: **ViReal64**

This control specifies the L.O. Frequency between 3GHz and 9MHz.

Default Value: Float

Valid Range:

- Minimum 3.00000GHz
- Maximum 9.00000GHz

Default:

- Minimum 3.00000GHz

RETURN VALUE

This control contains the status code returned by the function call.

Status Codes:

| <u>Status</u> | <u>Description</u> |
|---------------|---|
| 0 | No error (the call was successful). |
| 3FFF0005 | The specified termination character was read. |

| | |
|----------|---|
| 3FFF0006 | The specified number of bytes was read. |
| BFFF0000 | Miscellaneous or system error occurred. |
| BFFF000E | Invalid session handle. |
| BFFF0015 | Timeout occurred before operation could complete. |
| BFFF0034 | Violation of raw write protocol occurred. |
| BFFF0035 | Violation of raw read protocol occurred. |
| BFFF0036 | Device reported an output protocol error. |
| BFFF0037 | Device reported an input protocol error. |
| BFFF0038 | Bus error occurred during transfer. |
| BFFF003A | Invalid setup (attributes are not consistent). |
| BFFF005F | No listeners condition was detected. |
| BFFF0060 | This interface is not the controller in charge. |
| BFFF0067 | Operation is not supported on this session. |

PM20309_SET_REF

```
ViStatus PM20309_set_ref (ViSession instrumentHandle, ViUInt16 selectRef);
```

PURPOSE

This function sets the 10MHz reference signal to internal-output on, internal-output off, and external.

PARAMETER LIST**instrumentHandle**

Variable Type: **ViSession**

This control accepts the **InstrumentHandle** returned by the **Initialize** function to select the desired instrument driver session.

Default Value: None

selectRef

Variable Type: **ViUInt16**

This control specifies the 10MHz reference control line to internal-output on, internal-output off, and external.

Variable type: **ViUInt16**

Valid Range:

| | |
|-----------------------|---|
| Internal (Output ON) | 0 |
| Internal (Output OFF) | 1 |
| External (Output ON) | 2 |
| External (Output OFF) | 3 |

Default:

| | |
|----------------------|---|
| Internal (Output ON) | 0 |
|----------------------|---|

RETURN VALUE

This control contains the status code returned by the function call.

Status Codes:

| <u>Status</u> | <u>Description</u> |
|---------------|---|
| 0 | No error (the call was successful). |
| 3FFF0005 | The specified termination character was read. |
| 3FFF0006 | The specified number of bytes was read. |
| BFFF0000 | Miscellaneous or system error occurred. |
| BFFF000E | Invalid session handle. |
| BFFF0015 | Timeout occurred before operation could complete. |
| BFFF0034 | Violation of raw write protocol occurred. |
| BFFF0035 | Violation of raw read protocol occurred. |
| BFFF0036 | Device reported an output protocol error. |
| BFFF0037 | Device reported an input protocol error. |
| BFFF0038 | Bus error occurred during transfer. |
| BFFF003A | Invalid setup (attributes are not consistent). |
| BFFF005F | No listeners condition was detected. |
| BFFF0060 | This interface is not the controller in charge. |
| BFFF0067 | Operation is not supported on this session. |

PM20309_UPDATE_REGISTER_VALUE

```
void PM20309_update_register_value (ViUInt16 registerValue_IN, ViUInt16  
registerMASK, ViUInt16 subRegisterValue, ViPUInt16 registerValue_OUT);
```

PARAMETER LIST

registerValue_IN

Variable Type: **ViUInt16**

registerMASK

Variable Type: **ViUInt16**

subRegisterValue

Variable Type: **ViUInt16**

registerValue_OUT

Variable Type: **ViUInt16** (passed by reference)

This Page Intentionally Left Blank

6

HARDWARE REGISTER INTERFACE

INTRODUCTION

The Phase Matrix 20309 is a register-based, A16/A24, VXIbus Instrument. The A16 configuration registers contain basic information about the module, including the manufacturer ID, the device type, status/control, and the A24 offset address. All programming of the 20309 is accomplished by writing to the control registers located in the A24 address space. The function of each register is defined in this section.



BASIC CONFIGURATION REGISTERS

MANUFACTURER ID REGISTER (READ-ONLY)

Manufacturer ID Register (b+00_{HEX})

| | | | | | | | | | | | | | | | | |
|-------|-------------|----|----|----|----|----|---|---|---|---|---|---|---|---|---|---|
| Bit # | 15 | 14 | 13 | 12 | 11 | 10 | 9 | 8 | 7 | 6 | 5 | 4 | 3 | 2 | 1 | 0 |
| Write | Not Defined | | | | | | | | | | | | | | | |
| Read | 1 | 1 | 0 | 0 | 1 | 1 | 1 | 0 | 0 | 1 | 1 | 0 | 0 | 0 | 0 | 0 |

Bits 0 through 11 of the Manufacturer ID Register contain the manufacturer’s ID. Bits 12 and 13 establish the address space supported. Bits 14 and 15 establish the device class.

The Manufacturer ID number for Phase Matrix is 3680. This number is programmed into bits 0 through 11 of the Manufacturer ID Register and cannot be changed.

$$\text{Phase Matrix Manufacturer ID \#} = 3680 \text{ decimal} = 1110\ 0110\ 0000 \text{ binary}$$

The 20309 utilizes both A16 and A24 addressing modes. Per the VXIbus standard, bits 12 and 13 identify the addressing modes supported by the instrument. For instruments supporting A16/A24 addressing modes, both bits 12 and 13 have values of zero.

$$\text{Address Space} = \text{A16/A24} \Rightarrow \text{b12} = 0 \text{ and } \text{b13} = 0$$

Per the VXIbus standard, bits 14 and 15 indicate the device class. For register-based instruments, both bits 14 and 15 have values of one.

$$\text{Device Class} = \text{Register Based} \Rightarrow \text{b14} = 1 \text{ and } \text{b15} = 1$$

DEVICE TYPE REGISTER (READ ONLY)

Device Type Register (b+02_{HEX})

| Bit # | 15 | 14 | 13 | 12 | 11 | 10 | 9 | 8 | 7 | 6 | 5 | 4 | 3 | 2 | 1 | 0 |
|-------|-------------|----|----|----|----|----|---|---|---|---|---|---|---|---|---|---|
| Write | Not Defined | | | | | | | | | | | | | | | |
| Read | 1 | 1 | 0 | 0 | 0 | 0 | 0 | 1 | 0 | 0 | 1 | 1 | 0 | 1 | 0 | 1 |

← Required Memory →
← Model Code →

Bits 0 through 11 of the Device Type Register contain the model code for the instrument. For the Phase Matrix 20309, the model code is 309.

$$\text{Model Code} = 309 \text{ decimal} = 0001\ 0011\ 0101 \text{ binary}$$

Bits 12 through 15 of the Device Type Register establish the memory requirements for A16/A24 and A16/A32 devices. The resource manager uses this information when allocating memory for the system.

The following formula is used to determine the contents of bits 12 through 15 based on the memory requirements of the instrument:

$$\text{Required memory} = 256^a \times 2^{23-m}$$

where: a = contents of address space field in ID register.

a = 00 for the 20309.

m = required memory in integer increments of 2^n .

The 20309 needs 1304 bytes, so the allotted memory is 2048 bytes.

$$2^n = 2048 \Rightarrow n = 11$$

$$2^{11} = 2^{(23-12)} \Rightarrow m = 12$$

$$12 \text{ decimal} = 1100 \text{ binary}$$

$$\text{Device Type Register} = 1100\ 0001\ 0011\ 0101$$



STATUS/CONTROL REGISTER (READ-ONLY)

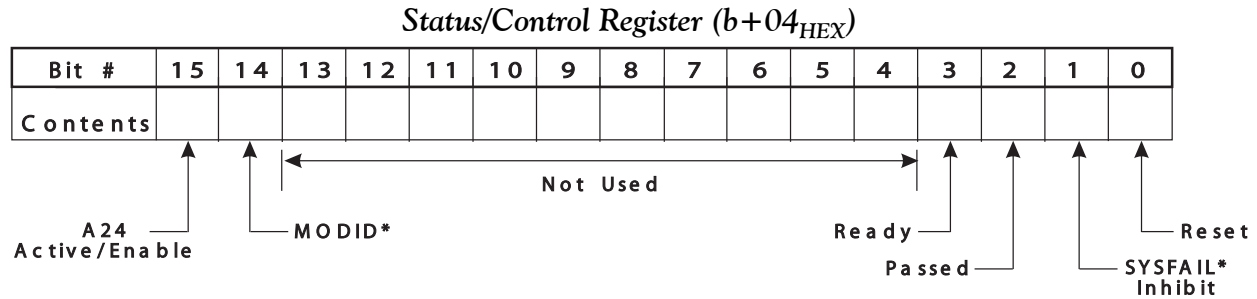

This register provides status information for the 20309. At power-up, the 20309 goes through an initialization routine and writes a one (1) to bit 3 of the Status Register when the initialization routine is complete. If the 20309 does not detect a problem during the initialization routine, it writes a one (1) to bit 2, indicating that it is ready to begin normal operation. At power-up, the resource manager reads this register to verify that the 20309 has passed initialization and is ready to execute commands.

OFFSET REGISTER FOR A24 (READ/WRITE)

The Offset Register contains the base address of the A24 address space. At power-up, in response to the requirement contained in the Device Type register, the resource manager assigns the 20309 a two-kilobyte block of A24 address space and writes the offset address to the A16 Offset-Address Register. This offset address is used when performing reads and writes to the A24 address space. The address of the Offset Register is (b+04_{HEX}).

A16 REGISTERS 08_{HEX} - 3F_{HEX} NOT USED

A24 REGISTERS

| Offset | Description |
|---|---------------------------------|
| 000 _{HEX} – 1FF _{HEX} | Not used |
| 200 _{HEX} (Write) | Not used |
| 200 _{HEX} (Read) | Status register (16 bits) |
| 202 _{HEX} (Write) | Not used |
| 204 _{HEX} (Write) | Not used |
| 206 _{HEX} (Write) | Not used |
| 208 _{HEX} (Write) | Synthesized LO Control Register |
| 20A _{HEX} (Write) | Synthesized LO Data Register |

STATUS REGISTER (OFFSET 200_{HEX}) READStatus Register (Offset + 200_{HEX})

| Bit # | 15 | 14 | 13 | 12 | 11 | 10 | 9 | 8 | 7 | 6 | 5 | 4 | 3 | 2 | 1 | 0 |
|-------|-----------------|-----|-----|-----|----|----|---|---|---|---|---|----|-----|-----|-----|-----|
| Write | Not Implemented | | | | | | | | | | | | | | | |
| Read | | LO3 | LO2 | LO1 | | | | | 1 | 1 | 1 | +5 | -10 | -21 | +21 | +10 |

Bits 0-15

This register contains 16-bit status information. A high bit indicates that the corresponding hardware is functional. Thus, reading XFFFH from this register indicates that the unit is completely functional.

| Bit | Description |
|-----|---|
| 0 | +10 Volt supply |
| 1 | +21 Volt supply |
| 2 | -21 Volt supply |
| 3 | -10 Volt supply |
| 4 | +5 Volt supply |
| 5 | Always high (not used) |
| 6 | Always high (not used) |
| 7 | Always high (not used) |
| 8 | Not used |
| 9 | Not used |
| 10 | Not used |
| 11 | Not used |
| 12 | LO 1 Detect (Indicates that 3–9 GHz LO is present) |
| 13 | LO 2 Lock Detect (Indicates that 3.25 GHz LO is locked) |
| 14 | LO 3 Lock Detect (Indicates that 228 MHz LO is locked) |
| 15 | Not used |



LO SYNTHESIZER CONTROL REGISTER (OFFSET 208_{HEX})

LO Synthesizer Control Register (Offset 208_{HEX})

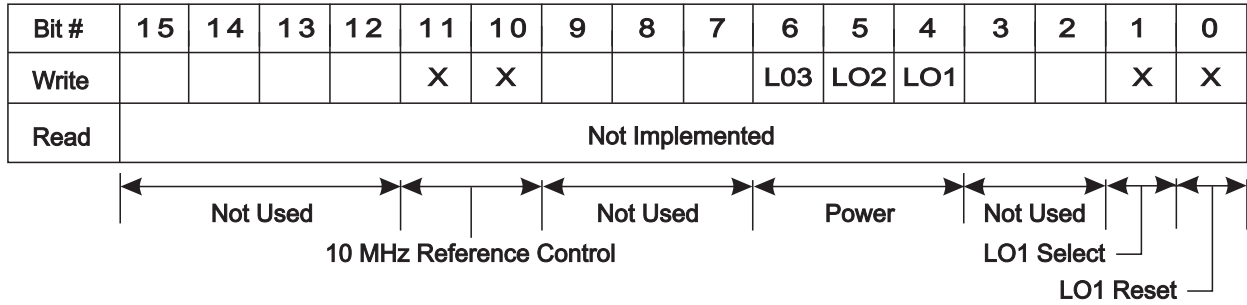

- Bit 0 **LO_RESET** — This bit resets the LO Synthesizer microprocessor when it is pulled low.

 - Bit 1 **LO_SELECT** — This bit allows transmission of data to the LO Synthesizer. This pin must be pulled to 0 before sending data to the DATA Register. When all the data bytes are sent, this pin must be pulled to 1.

 - Bits 2, 3 Not used

 - Bit 4 **L01_PWR** — This bit controls the DC power to LO 1. The DC power to the LO is turned OFF when this bit is set to 1 and turned ON when it is set to 0.

 - Bit 5 **L02_PWR** — This bit controls the DC power to LO 2. The DC power to the LO is turned OFF when this bit is set to 1 and turned ON when it is set to 0.

 - Bit 6 **L03_PWR** — This bit controls the DC power to LO 3. The DC power to the LO is turned OFF when this bit is set to 1 and turned ON when it is set to 0.

 - Bit 7-9 Not used

 - Bits 10, 11 10 MHz Reference control — Bit 10 controls the switch between Internal and External, while bit 11 turns the output ON or OFF.
- | Bit 10 | Bit 11 | = | Description |
|--------|--------|---|-----------------------|
| 0 | 0 | = | Internal (Output ON) |
| 0 | 1 | = | Internal (Output OFF) |
| 1 | 1 | = | External (Output OFF) |
| 1 | 0 | = | External (Output ON) |
-
- Bits 12-15 Not used

LO SYNTHESIZER (LO1) DATA REGISTER (OFFSET 20A_{HEX})

This oscillator is tunable between 3 GHz and 9 GHz in 1 Hz steps. It is essential that this oscillator be programmed to the appropriate frequency for each given input frequency and output IF mode. Use the formulas in the table below to calculate the frequency for this oscillator.

Bits 0 -7 LO Data Byte — ASCII data bytes are sent through this register to the LO Synthesizer. The data is sent MSB-first. The format for the data is:

FMMMM.MMMMMM

where **F** is always sent first, and **MMMM.MMMMMM** is the frequency in MHz. Trailing zeros can be omitted. For example, **F5500.4** sets the LO Synthesizer frequency to 5.5004 GHz. The string is transmitted from left to right (MSB first).

LOCAL OSCILLATOR 2 (LO 2)

This oscillator is not tunable and is set to a fixed frequency of 3.25 GHz.

LOCAL OSCILLATOR 3 (LO 3)

This oscillator is not tunable and is set to a fixed frequency of 228 MHz.



This Page Intentionally Left Blank



VXIbus

INTRODUCTION

This VXIbus overview is from the VXIbus Specification, revision 1.3.

The goal of the VXIbus is to define a technically sound modular instrument standard based on the VMEbus that is open to all manufacturers and is compatible with present industry standards.

VXIbus is an acronym for VMEbus extensions for Instrumentation. The VXIbus specification details the technical requirements of VXIbus compatible components, such as mainframes, backplanes, power supplies, and modules. Before studying the VXIbus architecture, one should become familiar with the VMEbus and its specifications.

VMEbus BACKGROUND

The VMEbus is an open system architecture primarily focused at computer systems, though there presently is a limited offering of instrumentation. VMEbus modules are approximately six inches deep and come in two heights, about four and nine inches. The VXIbus specification refers to these as the A and B sizes, respectively. The precise dimensions are specified by the Eurocard standard, which describes a family of printed circuit boards and their associated DIN connector locations. VMEbus modules are designed for 0.8 inch slot to slot spacing. The A size board has a single 96 pin connector known as P1, while the B size may include a P1 and P2 connector. Each of these DIN connectors consists of three rows of 32 pins apiece on 0.1 inch centers. Typically, these boards are positioned vertically in a frame with the P1 connector closest to the top. Neither the VMEbus nor the VXIbus mandates a physical orientation, since orientation is only an implementation issue not needed for compatibility. Many VMEbus systems are designed to accept boards horizontally.

The VMEbus specification allows a maximum of 21 modules. However, if installed vertically in a mainframe intended for mounting in a standard 19 inch rack, 20 is the practical maximum. VMEbus makes no particular provision for an extension chassis or frame to frame communication. Multiple frame systems can be created by electrically buffering the VMEbus (at the loss of some bandwidth between cages) or by using standard data communication links that disguise the



underlying VMEbus architecture. There are no EMC (electromagnetic compatibility) requirements dictated by VMEbus, either conducted or radiated, nor are there power dissipation limits or chassis cooling requirements. VMEbus has left these issues to the system integrator, while VXIbus addresses these issues more rigorously.

Although electrically and logically similar to the 68000 microprocessor architecture, the VMEbus interface has been specified broadly enough that it is not dependent on any particular processor, and many processors are already supported on VMEbus, including the 80386. Many of the simpler VMEbus boards do not have processors at all.

A minimum VMEbus system requires only the P1 connector. All handshaking, arbitration, and interrupt support exists on P1, with P2 used to expand the system to 32 bits of address and data (A32 and D32). P1 will support 16 bit and 24 bit addressing (A16 and A24), as well as 8 and 16 bit data paths (D08 and D16). The extra lines needed for A32 and D32 are contained on the center row of P2, while the outer rows are user defined. These undefined pins are typically used for interface connections, such as allowing a module to drive a chassis mounted connector, access an internal disk drive, or provide for module to module communication. VSB (VMEbus Subsystem Bus) is a standard “subsystem bus” that has defined P2 as an additional communication path for up to six modules. Multiple VSBs may exist within any one VMEbus system. This is important to note, because VXIbus defines a subsystem of up to 13 modules and, like VSB, multiple VXIbus subsystems may exist within any one VXIbus system.

THE VXIbus EXTENSIONS

VXIbus retains P1 and the center row of P2 exactly as defined by VMEbus. This includes the 5 volt and æ12 volt power pins on P1, and the additional 5 volt pins on P2. VXIbus includes the A and B card sizes, and these modules remain totally VMEbus compatible. However, VXIbus has made substantial additions to the VMEbus specification oriented towards instrumentation that can best be described as an electromechanical superset and a logical subset.

VXIbus MODULES

VXIbus has added two Eurocard module sizes of about 13 inch depth referred to as the C and D sizes. These modules are 9 and 14 inches high respectively, and are placed on 1.2 inch centers. The C Eurocard is the same height as the VMEbus B size board, and may sport both the P1 and P2 connectors. The D size module is a triple high Eurocard that may include a P3 connector in addition to P1 and P2. The 1.2 inch module width allows feasible implementation of high density instrumentation modules while allowing enough space for shielding both sides of a module and inserting an optional chassis shield. It also has the added benefit of allowing a high degree of compatibility with the shorter and narrower A and B sizes by allowing them to be mounted on full length board carriers or adapters. These carriers/adapters may also shield the sides of standard VMEbus cards, giving them a high degree of electromagnetic compatibility with VXIbus systems.

VXIbus SUBSYSTEMS

A VXIbus system may have up to 256 devices, including one or more VXIbus subsystems. A VXIbus subsystem consists of a central timing module referred to as Slot 0 with up to 12 additional instrument modules. P2 and P3 are completely defined in a VXIbus subsystem. These 13 modules conveniently fill a standard 19 inch cabinet when mounted vertically on 1.2 inch centers. Many VXIbus systems will consist only of a single frame with these 13 modules. A common configuration will load the Slot 0 module with system resources such as the VXIbus mandated timing generation, the VMEbus required system controller functions, and a data communication port such as IEEE 488 or RS-232. Slot 0 may also include optional instrumentation. The other positions are general purpose slots for the user to mix and match modules. A single VXIbus subsystem may have less than 12 additional slots, but may not have more. Any combination of VXIbus subsystems may exist within a VXIbus system. For instance, one VXIbus system may consist of a frame with one Slot 0 and 12 VXIbus modules extended to another frame that has a Slot 0 adjacent to three instrument slots, another Slot 0 with five instrument slots, and four standard VMEbus slots of undefined P2.

P2 CONNECTOR DEFINITION

As mentioned previously, a VXIbus subsystem defines all P2 and P3 pins. The VXIbus P2 adds a 10 MHz ECL clock, ECL and analog supply voltages, ECL and TTL trigger lines, an analog summing bus, a module identification line, and a daisy chain structure known as the local bus. The trigger lines serve primarily as resources for signaling between instruments in a VXIbus subsystem, while the local bus lines are preferred for use within a multiple module instrument set (adjacent slots). The daisy chain local bus use is left to the module manufacturer to define, and several classes of electrical signals are permitted. Allowed signals are TTL, ECL, low voltage analog, and analog up to 42 volts. A keying mechanism near the faceplate indicating that module's local bus class prevents incompatible classes from accidentally being placed adjacently and potentially causing a destructive condition. Typical uses of the local bus include creating an internal analog bus or a chain of serial digital signal processors. There are a total of 24 local bus pins on P2, 12 lines in and 12 lines out for each slot; thus creating a 12 line bus that may or may not be passed on to adjacent slots.

P3 CONNECTOR DEFINITION

The VXIbus P3 connector adds many of the same resource types as described for P2, but is aimed at higher performance instrumentation. Included on P3 is a 100 MHz clock and sync signal, additional power pins of the same supply voltages, more ECL trigger lines, and 24 additional lines (48 pins) of daisy chain local bus. Also defined on P3 is a "star" trigger system where precision ECL trigger signals are routed through Slot 0 acting as a cross point switch. This allows very precisely matched trigger timing between modules regardless of module position.

VXIbus SYSTEM ARCHITECTURE

The VXIbus device protocols define how modules are granted non-conflicting portions of the VMEbus address space. A device is typically a single module, but this is not required. Several devices may exist on a single module, and a single device may consist of multiple modules. 256



devices may exist in any one VXIbus system, and are referred to by logical device address ranging from 0 to 255. A VXIbus system configuration space is defined in the upper 16K of the 64K A16 address space. Each device is granted a total of 64 bytes in this space, which is sufficient for many of the simpler devices. Devices requiring additional address space have their address requirements readable in a defined register in the A16 address space. A “resource manager” reads this value shortly after power-on, and then assigns the requested memory space by writing the module’s new VMEbus address into the device’s offset register. This method positions a device’s additional memory space in the A24 (16 Mbyte) or A32 (4 Gbyte) address space. If present day VMEbus cards are used in a system, the resource manager must position the VXIbus devices around the space taken by the standard VMEbus cards.

Higher level communication protocols are defined to allow sharing of interface modules and other devices by multiple manufacturers.

B

FUNCTIONAL BLOCK DIAGRAM

FUNCTIONAL BLOCK DIAGRAM

This section provides the functional block diagram for the Phase Matrix 20309 VXIbus Synthesized Signal Source.



This Page Intentionally Left Blank

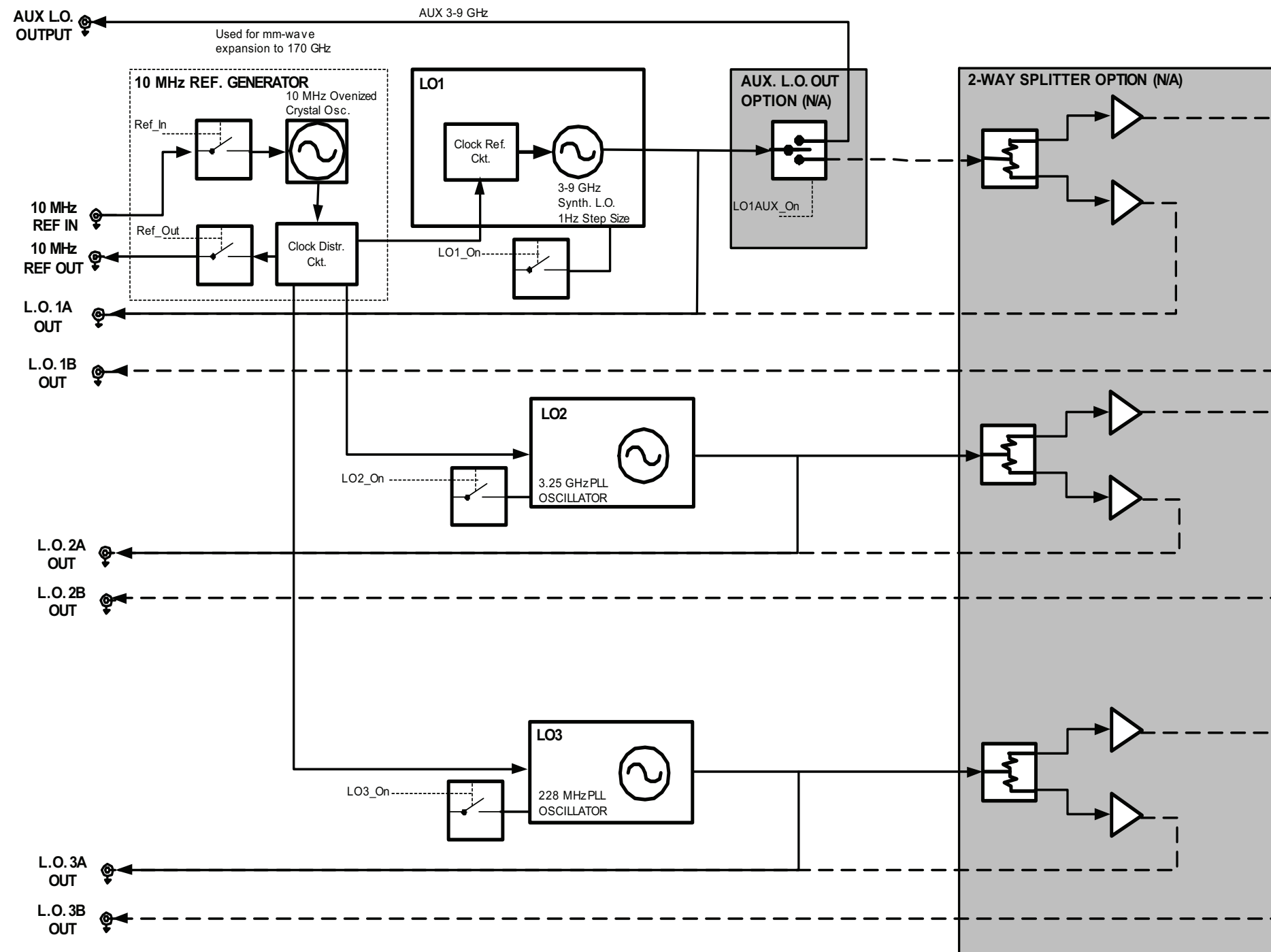

Figure A-1. Model 20309 Synthesized Signal Source Block Diagram

This Page Intentionally Left Blank